



**POLYTECH**

Peter the Great  
St.Petersburg Polytechnic  
University

# The system for comparing 3D models in patent expertise: algorithms and approaches for 3D models processing

Vladimir Muliukha, Aleksei Lukashin,

Peter the Great St. Petersburg  
polytechnic university



Dr. Alexey Lukashin –  
associate professor and  
head of supercomputer  
center – Higher school of  
Artificial Intelligence  
Technologies in Institute  
of computer science and  
cybersecurity



Dr. Vladimir Muliukha –  
Higher school of Artificial  
Intelligence Technologies in  
Institute of computer  
science and cybersecurity

- 2018-2019 – Research for methods and algorithms of 3D models comparison.
- July 2020 г. – Changes in law and regulation allowing applicants to submit 3D models as a part of the patent application.
- October 2020 – start of 3D information system development (IS3D)
- January 2021 – IS3D operates in production and supports experts in patent expertise
- June 2021 – IS3D provides search functionality

Filing	Processing	Storage	Publication	Exchange
STL, STEP IGES, OBJ X3D, DWF, DWG, U3D X3D, 3DM	<STEP, initial file, hash/descriptor file for searching>		Protected format like 3Dpdf	STEP or hash/descriptor file for searching

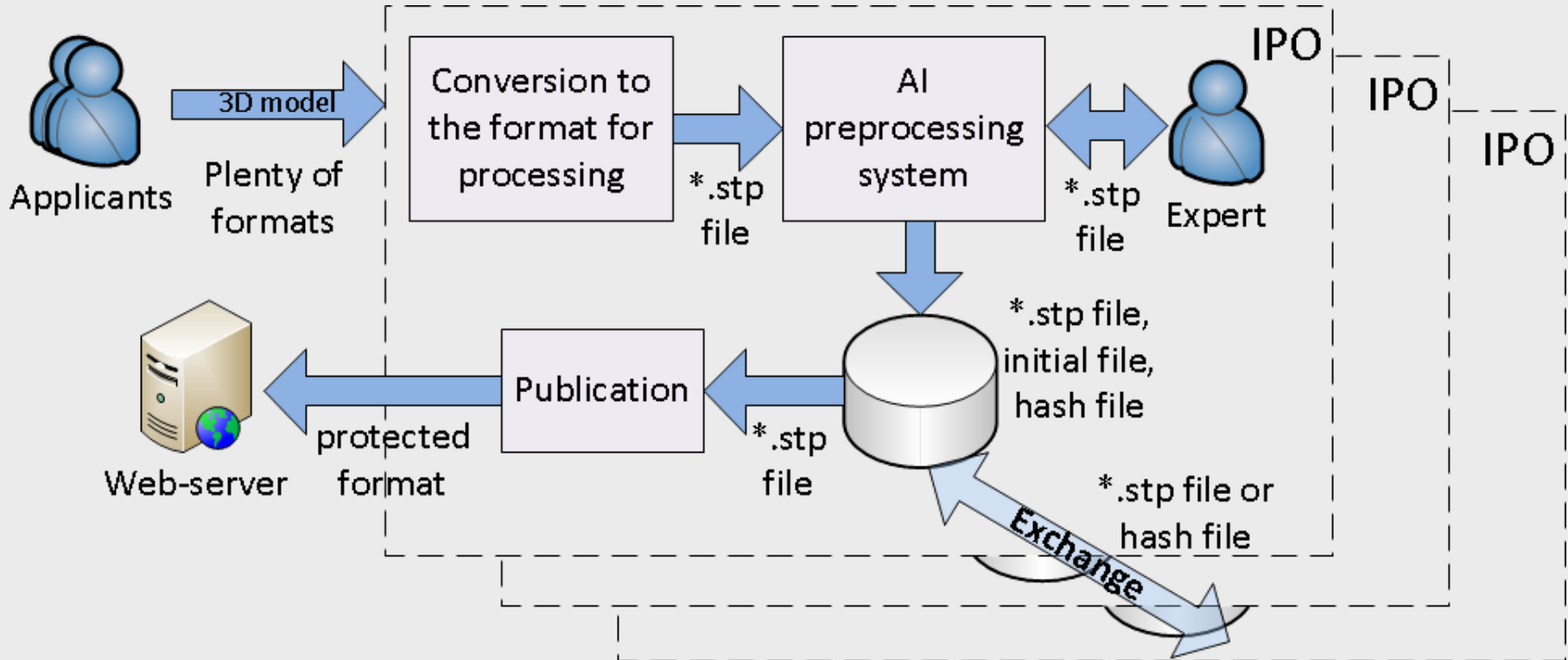

- Industrial design
- Patents
- Trademarks

Each type of application requires different workflows and business processes, but the main purpose of a system is to search and work with 3D models.

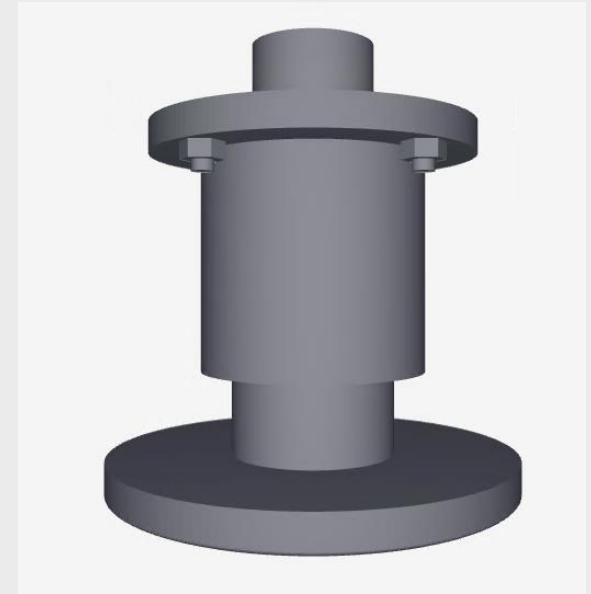

- Search for similar 3D models in the database (including model parts)
- Rank models by similarity
- Annotate models (view and make screenshots)
- Prepare the search report



Our users: FIPS experts

- Open and proprietary formats – stl, step, iges, obj, u3d, prc, ...
- Two main types
  - Transformation operations (e.g., step)
  - Description of surfaces (e.g., stl)
- Models might consist of parts
- Models might have textures and materials information

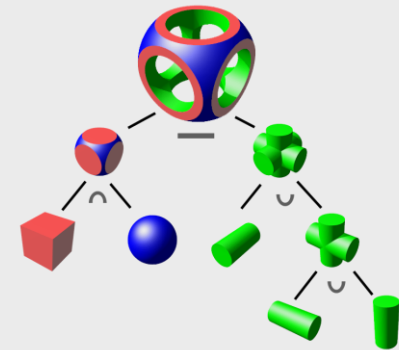
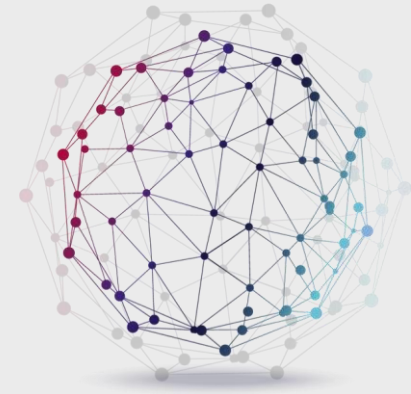

- Comparison of point clouds
- **Invariants calculation (i.e., model descriptors)**
- Comparison of 3D models projections

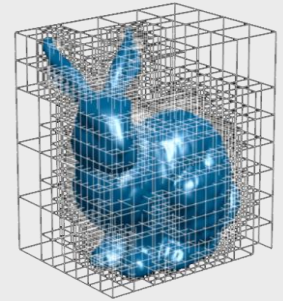

- Existing challenges:
  - Source data problems and how to build a good mesh
  - Models positioning
  - Models scaling
  - Heavy computations

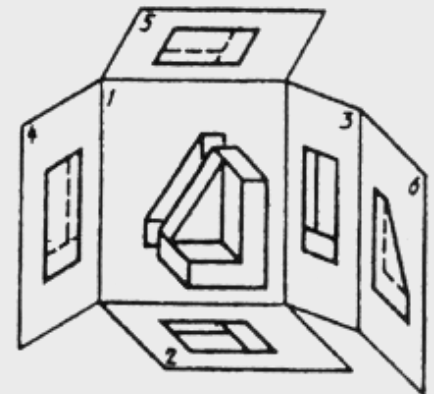

- Basic idea
  - Build a surrounding sphere
  - Spread points on it
  - Build segments for each pair of points
  - Find intersections with the model surface and calculate its lengths
  - Build a histogram of the normalized lengths distribution

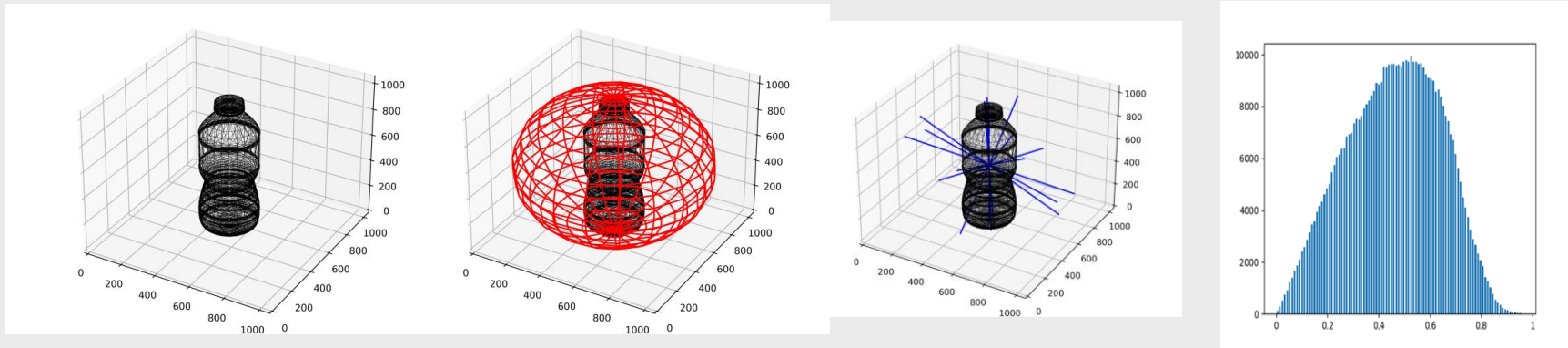

IS3D is using 4 different variations of histograms

Inspired by: Dejan V. Vranic. 3D Model Retrieval - Ph. D. Dissertation, University of Leipzig, 2005

Torus

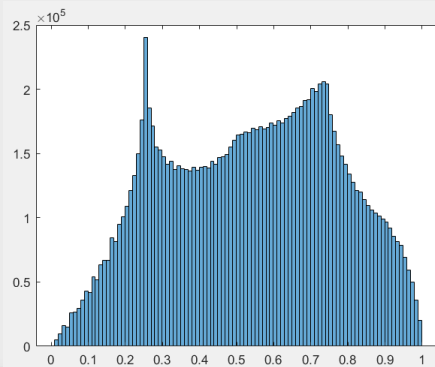
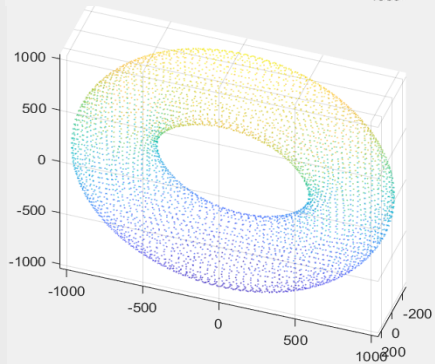
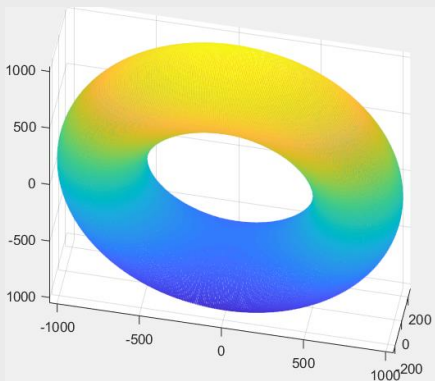

Shim

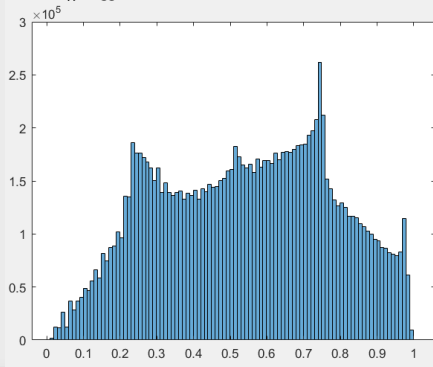
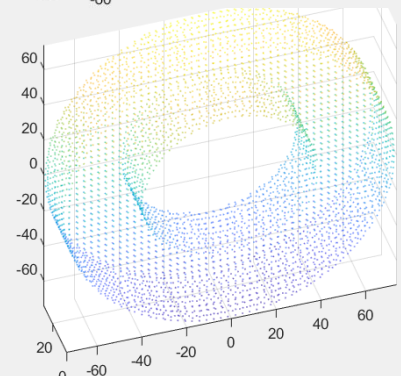
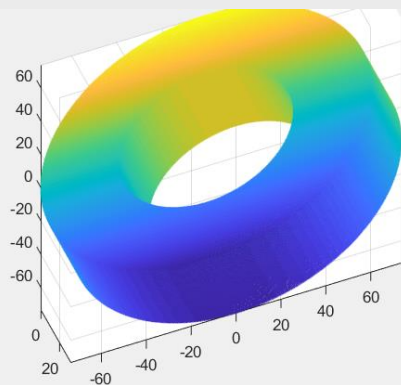

Cone

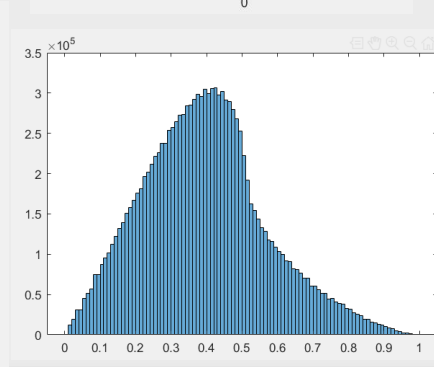
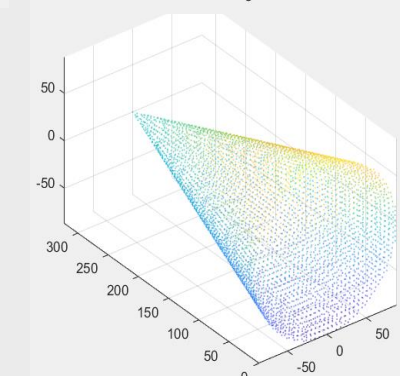
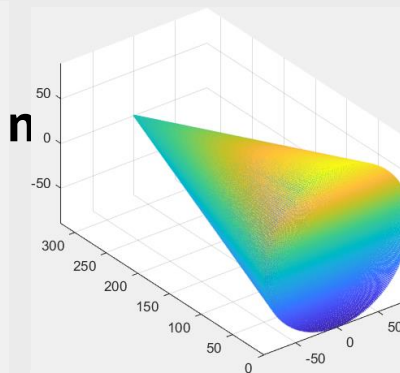

Rod

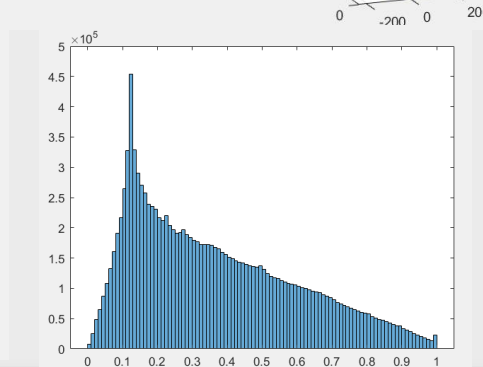
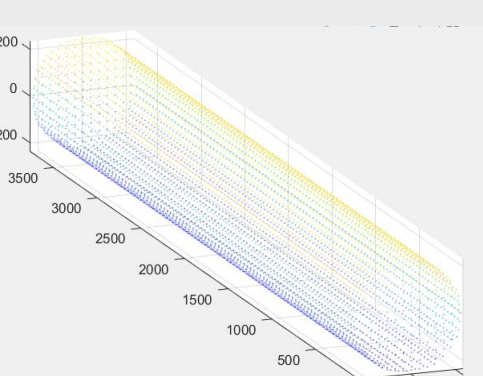
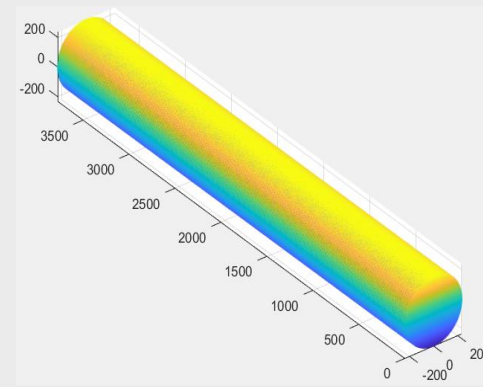

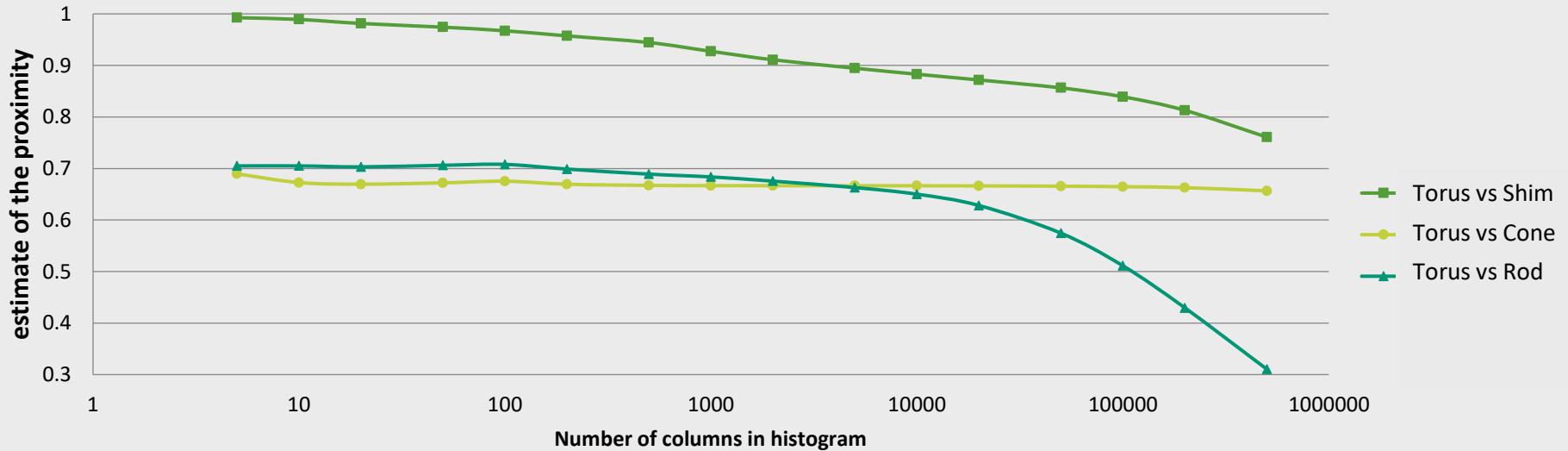
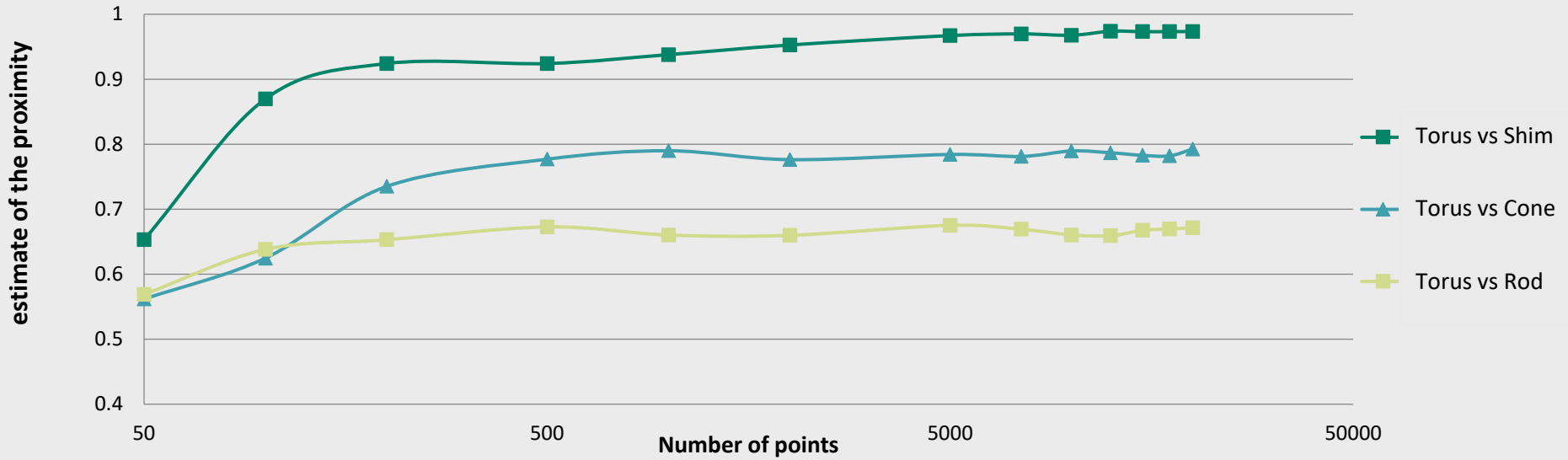











- Distance is computed as a sum of first and second norms of histogram differences

$$D = \frac{1}{2} \frac{\sum_i |h_{1i} - h_{2i}|}{\sum h_1 + \sum h_2} + \frac{1}{2} \sqrt{\frac{\sum_i (h_{1i} - h_{2i})^2}{(\sum h_1)^2 + (\sum h_2)^2}}, 0 \leq D \leq 1$$

## Why using machine learning for 3D models comparison

- Analytical method doesn't always work well and does not take into account how an expert works;
- An Expert during his work selects similar models – this data could build a training dataset;

Исходная модель	Похожая модель				Сформировать отчет
1  <span>ПМ</span>	 <span>ПО</span>	Номер заявки Патент <a href="#">2021000018</a> НЕ ЗАДАН	Время добавления в отчет 27.09.2021 18:24:41	Эксперт tester	   Удалить из отчета <span>81</span>
2  <span>ПМ</span>	 <span>ПО</span>	Номер заявки Патент <a href="#">2021000029</a> НЕ ЗАДАН	Время добавления в отчет 27.09.2021 18:24:39	Эксперт tester	   Удалить из отчета <span>84</span>

- Neural network model computes semantic similarity of 3D models.
- It is trained on the validated by the experts dataset where similar models are marked.
- During the training, the model tries to minimize the distance between similar models and maximize the distance between non-similar models.
- That allows taking expert's opinion into account vs using just math for difference calculation.

- Why a Siamese neural network?
  - Ability to train on small datasets.
  - Training is done by each-to-each comparison and rather a small number of models in the dataset allows production a large training set.

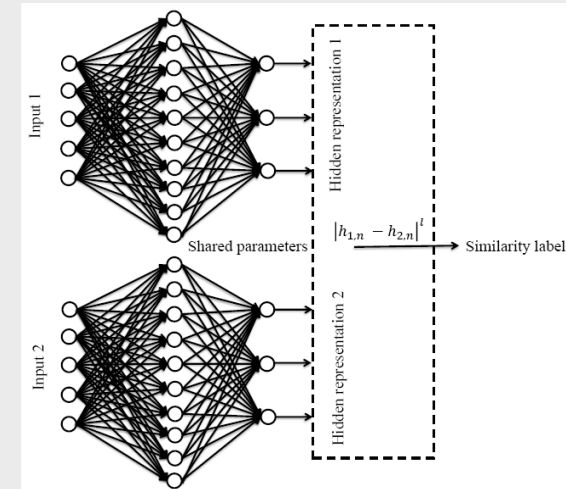

Input data – 3D model descriptors (vector of numbers)

Output data – neural 3D model descriptors (vector of numbers)

## Dataset development

- At the start of IS3D operation, we didn't have any expert data;
- To develop the dataset, we created an initial set of models and marked similar and non-similar with the help of FIPS experts;
- We calculated the required initial dataset size according to the neural network architecture: about 600 models.

### Trademarks:

1. Bottle
2. Tablet
3. Electronic cigarette
4. Matryoshka bottle
5. Package
6. Box
7. Candy
8. Bottle

### Patents

1. Rolling bearings
2. Gas pressure regulators
3. Conveyor rollers
4. Railroad vehicle buffers
5. Automobile suspensions
6. Quadcopters
7. Turbines
8. Wind turbines

### Industrial design

1. Cars
2. Washing machines
3. Furniture
4. Packaging
5. Tableware:
6. TVs

- How to measure the quality of 3D model comparison?
  - Analytical algorithm
  - At the first stage it is acceptable to make a manual search markup
  - Later, any results of expert searches will improve the quality
- Recall vs precision

- Model descriptor (histogram) – is a small vector of numbers which might have a visual representation;
- If patent agencies develop a common standard of 3D model descriptor, then this descriptor could be used for search in different databases without transferring the model itself;
- Descriptor could become an universal 3D model identifier (like URI);
- Descriptor could be published as a fingerprint of a 3D model.

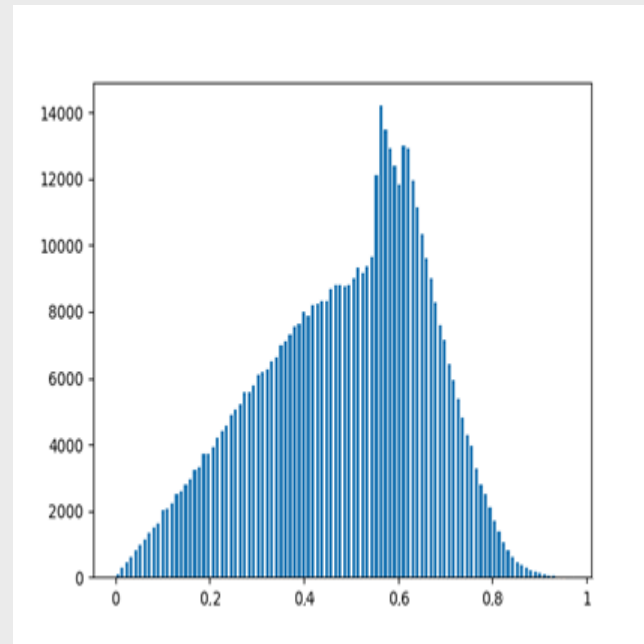

- There are complex models consisting of more than 100 parts;
- Should we search for each part during the patent expertise (model from X parts will cause more than X searches)?
- Many models have similar parts, e.g., screws and bolts. Should such simple parts participate in a search?

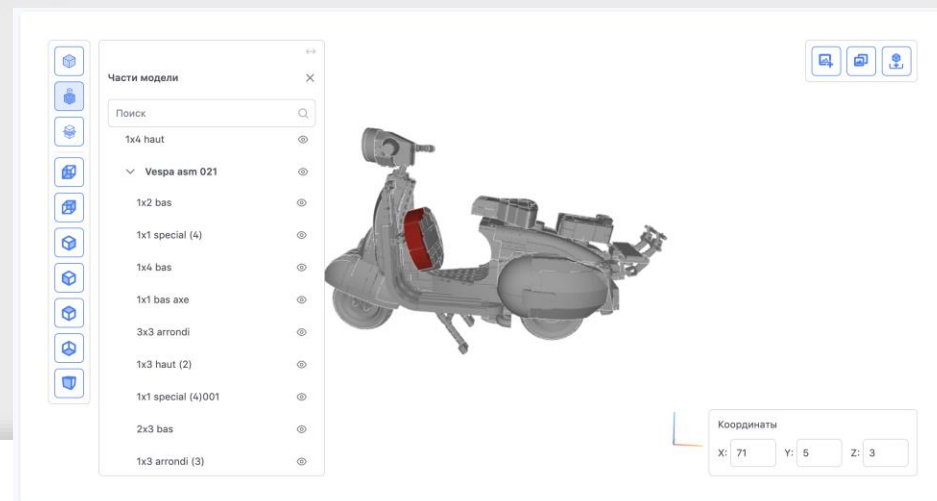



**POLYTECH**

Peter the Great  
St. Petersburg Polytechnic  
University

**Thanks for attention!**